



Cross-Connection Control and Backflow Prevention Policy Manual

2026



Serving Your Community, Preserving the Environment

Revised By: Central Alabama Water's System Development Department
May 2026

RIGHTS RESERVED

Publication of certain contents and figures herein shall not be reproduced for commercial use without permission in writing from Central Alabama Water

3600 First Avenue, North, P.O. Box 830110
Birmingham, Alabama 35283-0110

List of Abbreviations

AG – Air Gap Separation

DC – Double Check Valve Assembly

DCDA – Double Check Detector Assembly

RPDA – Reduced Pressure Principle Detector Assembly

DUC – Dual Check Valve Backflow Preventer

PVB – Pressure Vacuum Breaker

RP – Reduced Pressure Principle Backflow Preventer Assembly

Board - The term shall mean Birmingham Water Works Board.

List of Tables and Drawings

Table 1: Facility Type – Assigned Backflow Requirements	19
Table 2: Additional Systems / Facilities - Assigned Backflow Requirements	21
Table 3: Classification of Fire Protection Systems	23
Appendix A - Backflow Installation Drawings.....	28



Table of Contents

Central Alabama Water Policy Statement.....	7
Introduction.....	7
Section 1: Purpose	8
Section 2: Definitions	9
Air Gap Separation	9
Approved.....	9
Auxiliary Water Supply	9
Backflow.....	9
Backflow Prevention Device (Assembly) - Approved	9
Backpressure	9
Backsiphonage	9
Backflow Prevention Device Tester - Certified.....	10
Board	10
Consumer	10
Contamination	10
Cross-Connection.....	10
Cross-Connection Control by Containment.....	10
Double Check Valve Assembly.....	10
Double Check Valve Detector Assembly	10
Dual Check Valve Backflow Preventer	11
Degree of Hazard	11
Hazard - Health.....	11
Hazard - Pollution	11
Industrial Fluids.....	11
Industrial Piping System - Consumers.....	12
Point of Delivery.....	12
Reduced Pressure Principle Backflow Preventer Assembly	12
Reduced Pressure Principle Detector Assembly	12



Service Connection.....	12
Service Pipe	12
Water - Potable	12
Water Purveyor	13
Water System(s) - Consumers.....	13
Water - Used	13
Section 3: Causes of Backflow	13
Backsiphonage	13
Backpressure	13
Section 4: Responsibility	14
Board.....	14
Consumer	14
Certified Backflow Prevention Device Tester	15
Board Tester’s List.....	15
Section 5: Penalties for Non-Compliance	16
Discontinuance of Service	16
Discontinuance of Approval – Backflow Prevention Device Tester- Certified....	16
Unauthorized Use of Fire Hydrants	16
Section 6: Cross- Connection Control and Backflow Prevention Policy Requirements...	16
General Policy	16
New Service Connections	17
Existing Facilities.....	17
Maintenance and Testing of Backflow Preventers.....	17
Section 7: Typical Facilities and Systems Requiring Backflow Prevention Assemblies	18
List of Systems and Facilities- Assigned Backflow equirements.....	18
Additional List of Systems and Facilities	19-22
Thermal Expansion Control Device	22
Section 8: Fire Protection Systems.....	22-25
Booster Pumps.....	25
Jockey Pumps.....	25



Section 9: Installation of Devices.....	25
General Requirements	25
Air Gap Separation (AG).....	26
Dual Check Valve Backflow Preventer (DUC).....	26
Double Check Valve Assembly (DC)	26
Reduced Pressure Principle Backflow Preventer Assembly (RP).....	26
Double Check Detector Assembly (DCDA).....	27
Reduced Pressure Principle Detector Assembly (RPDA)	27
Pressure Vacuum Breaker (PVB).....	27
Backflow Installation Drawings.....	
Double Check (DC).....	28,31
Reduced Pressure Principle Backflow Assembly (RP).....	28,32
Parallel Installation.....	29
Air Gap Separation (AG).....	29
Dual Check Valve (DUC).....	30
Double Check Valve (DC) for 2 ½" and Larger.....	31
Detector Double Check Valve.....	33
Detector Reduced Pressure Principle Preventer.....	34
Pressure Vacuum Breaker (PVB).....	35,36



Central Alabama Water Policy Statement

STATEMENT OF POLICY ON CROSS-CONNECTIONS AND BACKFLOW PREVENTION

A statement of policy adopted by the Central Alabama Water (Board) derived from a policy statement of the American Water Works Association (AWWA).

The Board recognizes that as a water purveyor it has a responsibility to provide its customers at the service connection with water that is safe under all foreseeable circumstances. Thus, in the exercise of this responsibility the Board must take reasonable precaution to protect its distribution system from the hazards originating on the premises of its customers that may degrade the water in the Board's distribution system.

It is realized that cross-connection control and plumbing inspections on premises of its customers are regulatory in nature and should be handled through the authority or the plumbing-code enforcing agencies having jurisdiction. The Board, however, should be aware of any situation requiring inspection and/or re-inspections necessary to detect hazardous conditions resulting from cross connections. If, in the opinion of the Board, effective measures consistent with the degree of hazard have not been taken by the regulatory agency, the Board should take such measures as it may deem necessary to ensure that the Board's distribution system is protected from contamination. Such action would include the installation of a backflow prevention device, consistent with the degree of hazard, at the service connection (within 6 feet of the meter), or discontinuance of the service. In addition, customer use of water from the Board's distribution system for cooling or other purposes within the customer's system and later return of the water to the Board's distribution system is not acceptable and is opposed by the Board.

Introduction

The Board operates and maintains a public water supply system, authorized by Section 394 of Title 37 of the Code of Alabama (1940), amended by Act. No. 686, approved September 19, 1949. As a purveyor of potable water, the Board is required by law to establish and to operate a cross-connection control and backflow prevention program consistent with the extent of the system within its jurisdiction as mandated by the following governing bodies:

The Federal Safe Drinking Water Act of 1974 and Amendments of 1986 and 1996
Public Law 93-523.



The U.S. Environmental Protection Agency (EPA), Office of Water, 1989.

EPA Statement of Responsibility -

Under the provisions of the Safe Drinking Water Act of 1974 and Amendments of 1986, the Federal Government has established, through the EPA (Environmental Protection Agency), national standards of safe drinking water. The states are responsible for the enforcement of these standards as well as the supervision of public water supply systems and the sources of drinking water. The water purveyor (supplier) is held responsible for compliance to the provisions of the Safe Drinking Water Act, to include a warranty that water quality provided by operation is in conformance with the EPA standards at the source and is delivered to the customer without the quality being compromised as a result of its delivery through the distribution system. As specified in the Code of Federal Regulations [Volume 40, Paragraph 141.2, Section (c)].

The Alabama Department of Environmental Management Water Division - Water Supply Program Chapter 335-7-9 Cross-Connection Control Requirements. Effective: December 5, 1990, or latest amendments / revisions.

Statutory Authority: Code of Alabama 1975, Section 22-23-33, 22-23-49, 22-22A-5, 22-22A-6.

American Water Works Association (AWWA) – M14 Manual for Backflow Prevention and Cross-Connection Control Recommended Practices (latest edition).

In compliance with the Alabama Department of Environmental Management, Division 7, Water Supply Program, and originally promulgated by the Alabama State Board of Health on May 17, 1978, the following is the Board's Policy on Cross-Connection Control and Backflow Prevention.

Section 1: Purpose

The purpose of this policy is to protect the Board's potable water system against actual or potential cross-connections, backpressure and backsiphonage to eliminate or control existing cross-connections, actual or potential, by isolating within the consumer's premises or private property where it is probable that a pollution, contaminant, and/or system or plumbing hazard may be created by a water user; where toxic substances or materials dangerous to health are handled in tanks, piping systems or other vessels on the premises. More precisely, the policy is intended to prevent delivered water, water that has passed beyond the point of the service connection to the Board's public water system and into each private system of the consumer, from re-entering the Board's public distribution system.

Section 2: Definitions

Definitions contained in the Rules and Regulations of the Board governing service to customers shall also apply:

Air-Gap Separation (AG)

The term shall mean a physical separation between the free-flowing discharge end of a potable water supply pipeline and an open or non-pressure receiving vessel. An approved air-gap separation shall be at least two (2) times the inside diameter of the supply pipe measured vertically above the overflow rim of the vessel - with a minimum distance of one (1) inch (2.54 cm.).

Approved

The term as herein used in reference shall mean accepted by the Board as meeting an applicable specification or requirement.

Auxiliary Water Supply

The term shall mean any water supply on, or available to, a premise other than the Board's public potable supply. These auxiliary waters may include water from another purveyor's public potable water supply or any natural source such as a well, spring, river, stream, harbor, etc. or "used waters" or "industrial fluids".

Backflow

The term shall mean undesirable reversal of flow of water or mixtures of water and other liquids, gases, or other substances into the distribution pipes of the potable water supply from any source or sources.

Backflow Prevention Device (Assembly) - Approved

The term shall mean any approved testable assembly used to prevent backflow into a potable water system. The type of assembly used should be based on the degree of hazard, either existing or potential, and shall meet the latest standards of the American Water Works Association (AWWA) and The American Society of Sanitary Engineering (ASSE). The types of devices are:

- A. Double Check Valve (DC), defined below
- B. Reduced Pressure Principle (RP), defined below

Backpressure

The term shall mean a pressure higher than the supply pressure caused by pump, elevated tank, boiler, air/steam pressure, or any other means, which may cause backflow.

Backsiphonage

The term shall mean the upstream pressure to a consumer's piping system is reduced to a sub-atmospheric pressure.



Backflow Prevention Device Tester - Certified

The term shall mean a person who has proven their competency to make competent tests, repairs, overhaul, and make reports on backflow prevention assemblies to the satisfaction of the Board.

Board

The term shall mean Central Alabama Water.

Consumer

The term shall mean a customer who receives water service from the Board.

Contamination

The term shall mean an impairment of the quality of the potable water by any solid, liquid, or gaseous compound or mixture which creates a hazard to public health through poisoning or through the spread of disease.

Cross-Connection

The term shall mean any actual or potential connection or structural arrangement between two otherwise separate piping systems or any other source or system through which it is possible to introduce into any part of the potable system any used water, industrial fluid, gas, or substance. A service connection between the Board's potable water distribution system and the consumer's water system which is connected to a separate fire protection system or auxiliary water system whether by jumper connections, removable sections, swivel, or change-over devices and other temporary or permanent devices through which or because of which "backflow" can or may occur are considered to be cross-connections.

Cross-Connection Control by Containment

The term shall mean installation of an approved backflow prevention assembly at the water service connection to any consumer's premises where it is physically infeasible to find and permanently eliminate or control all actual or potential cross-connections within the consumer's water system.

Double Check Valve Assembly (DC)

The term shall mean an assembly composed of two independently acting, approved check valves, including tightly closing shut-off valves attached at each end of the assembly and fitted with properly located test cocks (see Section 9 for additional details). This assembly shall only be used to protect against a non-health hazard (i.e., pollutant).

Double Check Detector Assembly (DCDA)

The term shall mean a specifically designed assembly composed of a line-size approved double check valve assembly with a specific by-pass water meter and a meter-sized approved double check valve assembly. The meter shall register



accurately for only very low rates of flow and shall show a registration for all rates of flow (see Section 9 for additional details). This assembly shall only be used on a fire protection service to protect against a non-health hazard (i.e., pollutant).

Dual Check Valve Backflow Preventer (DUC)

The term shall mean a device composed of two in-line independently acting, approved check valves. This device is not testable and does not have shut-off valves at each end of the device or fitted with test cocks (see Section 9 for additional details). This device shall only be used for residential service and to protect against a non-health hazard (i.e., pollutant).

Degree of Hazard

The term shall be derived from the evaluation of conditions within a water using facility which can be classified as either a "pollutant" (non-health) or a "contaminant" (health) hazard. Establishing the degree of hazard is determined by the Board.

Hazard - Health

The term shall mean an actual or potential threat of contamination involving any substance that could cause death or illness, spread disease, or have a high probability of causing such effects.

Hazard - Pollutant

The term shall mean an actual or potential threat to the physical properties of the potability of the public potable water system, but which generally would not constitute a health or system hazard, as defined, but would constitute a nuisance or be aesthetically objectionable.

Industrial Fluids

The term shall mean any fluid or solution which may be chemically, biologically, or otherwise contaminated or polluted in a form or concentration such as would constitute a health, system, pollution, or plumbing hazard if introduced into an approved water supply. This may include, but not be limited to: polluted or contaminated used waters; all types of process waters and "used waters" originating from the public potable water system which may deteriorate in sanitary quality; chemicals in fluid form; plating acids and alkalis, circulated cooling waters connected to an open cooling tower and/or cooling waters that are chemically or biologically treated or stabilized with toxic substances; contaminated natural waters such as from wells, springs, streams, rivers, bays, harbors, seas, irrigation canals or systems, etc.; oils, gases, glycerin, paraffins, caustic and acid solutions and other liquid and gaseous fluids used in industrial or other processes or for firefighting purposes.



Industrial Piping System - Consumers

The term shall mean any system used by the consumer for transmission of or to confine or store any fluid, solid or gaseous substance other than an approved water supply. Such a system would include all pipes, conduits, tanks, receptacles, fixtures, equipment, and appurtenances used to produce, convey, or store substances which are or may be polluted or contaminated.

Point of Delivery

The term shall mean the terminal end of a service connection to the public water system. If a meter is installed at the end of a service line, then the point of delivery shall be the downstream end of the meter (see Section 2 "Service Connection").

Reduced Pressure Principle Backflow Preventer Assembly (RP)

The term shall mean an assembly containing two independently acting approved check valves together with a hydraulically operating, mechanically independent pressure differential relief valve located between the check valves. The unit shall include properly located test cocks and tightly closing shut-off valves at each end of the assembly (see Section 9 for additional details). This assembly is designed to protect against a health hazard (i.e., contaminant).

Reduced Pressure Principle Detector Assembly (RPDA)

The term shall mean a specially designed assembly composed of a line-size approved reduced pressure principle backflow prevention assembly with a specific by-pass water meter and a meter-sized approved reduced pressure principle backflow prevention assembly. The meter shall register accurately for only very low rates of flow and shall show a registration for all rates of flow (see Section 9 for additional details). This assembly shall be used on a fire protection service to protect against a health hazard (i.e., contaminant).

Service Connection

The term shall mean the attachment of a consumer's service line to the Board's water main.

Service Pipe

The term shall mean a pipe used to conduct potable water from the meter to a point of use within the consumer's premises. A service pipe used for fire protection shall be the pipe from the service connection to the point of use within the premises.

Water - Potable

The term shall mean any water which, according to recognized standards of the health agency having jurisdiction, has been approved for human consumption.



Water Purveyor

The term shall mean the owner or operator of the potable water system supplying an approved water supply to the public. As used herein the terms water purveyor and the Board may be used synonymously.

Water System(s) - Consumers

The term shall include any water system located on the consumer's premises whether supplied by a public potable water system or an auxiliary water supply. The system or systems may be either a potable water system or an industrial piping system.

Water - Used

The term shall mean any water supplied by a water purveyor from a public potable water system to a consumer's water system after it has passed through the service connection and is no longer under the control of the water purveyor.

Section 3: Causes of Backflow

Major causes of backflow are outlined below under the two types of backflow – backsiphonage and backpressure.

Backsiphonage

The principal causes of backsiphonage are:

1. Breaks or repairs on the supply system piping which causes a negative pressure by water flowing to a lower point.
2. When water is withdrawn through an undersized piping system at a high velocity, the pressure in the pipe is reduced and the pressure differential created can cause a reverse flow from unprotected service connections.
3. Reduced supply main pressure due to high water withdrawn from firefighting, suction of a booster pump, water main flushing or water main breaks.

Backpressure

The principal causes of backpressure are:

1. Connection with auxiliary water systems having a higher pressure.
2. Connections to boilers, booster pumps and other pressure systems without backflow preventers.
3. Storage tanks or plumbing systems due to their elevation which could create sufficient reverse pressure.



Section 4: Responsibility

Board

The Board has primary responsibility for the prevention of contamination and pollution from entering the Board's potable water supply system. The Board's responsibility begins at the source of the public water supply and includes all the public water distribution system and ends at the service connection (point of delivery) to the consumer's water system. In addition, the Board shall determine the degree of hazard to the public potable water system. When the Board determines that a backflow prevention device is required to protect the public system, the Board shall require the consumer, at the consumer's expense, to install and maintain an approved backflow prevention device at each service connection.

Consumer

The consumer is responsible for preventing pollutants and contaminants from entering their potable water system(s) or the public potable water system, starting at the point of delivery from the Board's public potable water system and includes all their water systems. The consumer, at their own expense, shall install, operate, have tested, and maintained an approved backflow prevention assembly as directed by the authority having jurisdiction. The consumer shall maintain accurate records of test and repairs made to backflow prevention assemblies. The records shall be on forms approved by the Board and shall include the list of materials or replacement parts used. The backflow prevention assembly must be tested by an approved tester, at the consumer's expense, following installation of a new assembly, the required annual test, any repairs, overhaul, re-piping, or relocation of an existing assembly to ensure that it is in good operating condition and will prevent backflow. Tests, maintenance, and repairs of backflow prevention assemblies shall be made by an approved certified backflow prevention device tester and provided to the Board.

The consumer will always indemnify and hold harmless the Board, their officers, agents, and employees against all liability, claims of liability, any and all losses, cost of damage including death and loss of services and reasonable attorney's fees occurring, during or as a result of the failure of the consumer to properly maintain his system pursuant of the Cross-Connection Control and Backflow Prevention Policy of the Board. The consumer, at his expense, will defend the Board and its officers, agents and employees in any suit brought against them because of such breach.



Certified Backflow Prevention Device Tester

When employed by the consumer to test, repair, overhaul or maintain backflow prevention devices, a backflow prevention device tester will have the following responsibilities:

The tester will be responsible for making competent inspections and for repairing or overhauling backflow prevention devices and making reports of such repair to the consumer and responsible authorities on forms approved by the Board and/or health agency having jurisdiction.

The tester shall include the list of materials or replacement parts used. The tester shall be equipped with and be competent to use all the necessary tools, gages, manometers, and other necessary equipment to properly test, repair and maintain backflow prevention assemblies. It will be the tester's responsibility to ensure that original manufactured parts are used in the repair of or replacement of parts in backflow prevention assemblies. It will be the tester's further responsibility not to change the design, material, or operational characteristics of an assembly during repair or maintenance without prior approval of the approving authority.

A certified tester shall perform the work and be individually responsible for the competency and accuracy of all tests and reports. Each person who is certified to make competent tests or repairs, overhaul, and make reports on backflow prevention assemblies, shall be conversant with applicable laws, rules, and regulations, and shall have attended and successfully completed an approved Certification Program for Backflow Prevention Device Testers. All testers will adhere to the Board's System Development Department's Falsification Guidelines. Contact the Board's System Development Department for additional information on Guidelines.

Board Tester's List

In order to be placed on Board Tester's List, you must have a current backflow certification from an ACCREDITED backflow school. Contact the Board's System Development Department to establish a date to take the Board's backflow written test. A copy of your backflow certification must be given to a Board's Representative on the day of the test. A SEVENTY PERCENT (70%) passing rate must be obtained in order to be placed on the Board's Tester's List.

For an updated Tester's List, please contact the Board's System Development Department at:

Phone: (205) 244-4258 / (205) 244-4254

Email: back.flow@caw-al.gov



Section 5: Penalties for Non-Compliance

Discontinuance of Service

The Board shall deny or discontinue water service to a consumer if a required backflow prevention device is not installed, tested, and maintained; or if a cross - connection exists on the premises and there is inadequate backflow protection at the service connection. Water service shall not be restored to such premises until deficiencies have been corrected or eliminated to the satisfaction of the Board.

Discontinuance of Approval - Backflow Prevention Device Tester - Certified

The Board may revoke or suspend its approval of a certified tester for improper testing, maintenance, reporting or other unethical practices connected with these devices.

Unauthorized Use of Fire Hydrants

The use of fire hydrants without the Board's written authorization is prohibited. Offenders may be prosecuted for theft and/or the actual or potential pollution or contamination of the public water system from backflow (see Section 7).

Section 6: Cross - Connection Control and Backflow Prevention Policy Requirements

General Policy

It is a primary responsibility of the Board to evaluate the hazards inherent in supplying a consumer's water system. When a hazard or potential hazard to the public water system is found on the consumer's premises, the consumer shall install an approved and appropriate backflow prevention device at each service connection to the premises. The type and location of devices to be installed shall be determined by the Board.

When approved backflow prevention equipment has been provided by the consumer at the point of delivery, the Board shall no longer be legally responsible with the consumer's internal water system. The responsibility to evaluate internal hazards to the domestic water system is that of the Department of Buildings and Inspection and/or Health Agency having jurisdiction. Should there be a change in the use of water on the premises that would affect the type of hazard to the public water system, the consumer or agency having jurisdiction should inform the Board.



New Service Connections

Applications for a service connection to the Board's water mains shall be evaluated to determine the degree of hazard and the type of backflow prevention device that may be required at the point of delivery. The applicant may be required to complete a Cross-Connection Control Questionnaire. Where adequate plans and specifications are not available and no realistic evaluation of the proposed water uses can be determined, the consumer or his authorized agent may be required to install the maximum backflow protection at the service connection. For detailed instructions regarding installation specifications and freeze protection procedures please see the backflow assembly's manufacturer website.

Existing Facilities

The Board shall conduct inspections and/or surveys of a consumer's premises with existing service connections to determine the degree of hazard to the public water system. The customer shall be notified in advance of an inspection and the reasons for the inspection. Should the Board determine that a backflow prevention device is required at the point of delivery to the consumer's service, the Board shall notify the consumer in writing of the necessity to install an approved backflow prevention device. Refusal by a consumer to allow an inspection or the installation of a required backflow preventer, shall cause the Board to discontinue service for non-compliance.

Maintenance and Testing of Backflow Preventers

To assure the proper operation of backflow prevention devices, the consumer shall have thorough inspections and operation tests made within 30 days of installation and thereafter on an annual basis by an approved certified backflow prevention device tester (see Section 4 Responsibility - Consumer). For detailed instructions regarding maintenance and testing procedures please see the backflow assembly's manufacturer's website.

Alabama Department of Environmental Management

Code 335-7-9-.05

Effective: December 5, 1990, or latest amendments / revisions



Section 7: Typical Facilities and Systems Requiring Backflow Prevention Assemblies

- All commercial domestic services will require a reduced pressure principle backflow preventer assembly (RP). The following is a list of facilities that may endanger the public water system and should not be construed as being complete:

All churches will be required to have an RP, unless inspected and approved by the Board. Approved churches will need to meet the following criteria(s): Must not have an existing or proposed classroom(s) and/or daycare(s), a baptismal pool, or commercial style kitchen.

All beauty salons, barber shops, and nail salons will be required to have a RP, unless inspected and approved by the Board.

All apartment buildings are identified to be commercial-residential buildings. These buildings must have an RP. If any apartment building Domestic Master Meter is changed to meter individual apartment units, each unit must be assigned an individual RP to ensure the Board's public water system is protected.

All homes that have a pool will be required to have a DC, unless inspected and approved by the Board.

- Fire Systems (see Section 8)
- Irrigation Systems (see Section 7, Table 2)

Note: If a customer wants to remove the backflow requirement, the customer will have to disconnect their irrigation system from the water system. Please contact the Board's System Development Department for instructions.

- Residential backflow determined by hazard type (see Section 6: New Service Connections and Existing Facilities)

List of Systems and Facilities - Assigned Backflow Requirements

This list of facilities that may endanger the public water system is a guideline and should not be construed as being complete. The type and location of devices to be installed shall be determined by the Board. If there are questions regarding backflow requirements, please contact the Board's System Development Department.



Table 1: Facility Type - Assigned Backflow Requirements

Facility Type	Assigned Backflow Requirements AG – Air Gap Separation DC – Double Check Valve RP – Reduced Pressure Principle
Agricultural processing facilities	RP
Aircraft and missile plants	RP
Amusement parks	RP
Animal hospitals and clinics	RP
Apartments	RP
Automotive plants	RP
Beauty salons, barber shops, and nail salons (unless inspected and approved by the Board)	RP or (DC)
Beverage bottling plants	RP
Breweries	RP
Buildings (multistory) with or without booster pumps and/or water storage tanks	RP
Buildings with sewage ejectors	RP
Canneries, packing houses, and reduction plants	RP
Car wash	RP
Chemical plants	RP
Chemically treated water systems	RP
Churches (unless inspected and approved by the Board)	RP or (DC)
Dairies and cold storage plants	RP
Dental buildings	RP
Dye works	RP
Fertilizer plants and spray distributors	RP
Film laboratory or processing plant	RP
Fire systems (see Section 8)	DC or RP
Food processing plants	RP
Funeral homes	RP
Hospitals, clinics. Medical building, or office	RP
Irrigation system (see Section 7, Table 2)	DC or RP
Laboratories	RP



Laundry or dry-cleaning facilities (see Section 7, Table 2)	RP
Manufacturing, processing, and fabricating plants	RP
Mobile home parks	RP
Morgues and mortuaries	RP
Motion picture studios	RP
Multiple services to a single premise	RP
Nursing homes	RP
Oil and gas refineries, storage, or transmission facilities	RP
Paper production plants	RP
Pesticides (exterminating companies)	RP
Pet shops	RP
Plating plants	RP
Private wells	RP
Radioactive materials plant or facilities	RP or AG
Restricted, classified, or other closed facilities	RP or AG
Rubber plant	RP
Sand and gravel plants	RP
Schools (elementary, high, college, and technical)	RP
Sewer treatment plants and pumping stations	RP or AG
Shopping centers	RP
Swimming pools and ponds	RP
Tanneries	RP
Therapeutic tanks and hot tubs	RP
Waterfront facilities	RP
Any other facility the Board determines could endanger the public water system	RP

Table 2: Additional Systems / Facilities - Assigned Backflow Requirements

Facility Type	Assigned Backflow Requirements AG – Air Gap Separation DC – Double Check Valve RP – Reduced Pressure Principle
<p>Farming Operations -</p> <p>Poultry Houses with automatic proportioning pumps or feeder barrels for supplying water with live viruses or other medication, livestock watering troughs, diluting, and mixing of pesticides, insecticides and liquid fertilizers, hose bibs situated on premises with livestock, kennels or where chemicals are used.</p>	<p>RP</p>
<p>Irrigation (lawn sprinkler) Systems -</p> <p>Irrigation systems equipped with pumps, injectors, pressurized tanks, or facilities for injecting chemicals, such as fungicides, pesticides, herbicides, and other toxic or objectionable substances, and subject to contamination from submerged inlets/sprinkler heads and auxiliary supplies.</p>	<p>RP</p>
<p>Laundry and Drying Facilities -</p> <p>Laundry machines having under rim or bottom inlets, dry cleaning equipment, solvent reclaim facilities, storage tanks with recirculating pumps, dye vats with toxic chemicals, shrinking, bluing, and dyeing machines connected to recirculating systems, boilers, steam lines and heat exchanges.</p>	<p>RP</p>



<p>Fire Hydrants:</p> <p>The miscellaneous uses of water from fire hydrants by other than authorized personnel are prohibited, offenders may be prosecuted for theft and actual or potentially endangering the Board's public potable water supply with pollution or contamination. The Board may permit the use of water from a fire hydrant for construction or other purposes provided the applicant shall properly apply for and adhere to backflow prevention requirements on fire hydrant permits (degree of hazard).</p>	<p>RP or AG</p>
<p>Jockey Pumps:</p> <p>When a jockey pump (an auxiliary pump with high-head and low-capacity characteristics) is required to maintain elevated pressure within the consumer's system, an approved backflow prevention assembly shall be installed on the upstream side of the pump (see Section 9).</p>	<p>RP or AG</p>

Thermal Expansion Control Device

If water is heated in the consumer's water system that has been closed by the installation of a backflow preventer, a pressure reducing valve, or other checking devices, an approved Thermal Expansion Control Device should be installed by the consumer as required by the agency having jurisdiction, to limit the pressure build-up of the water heater.

Section 8: Fire Protection Systems

Fire Protection Systems Classified

An approved backflow prevention assembly and/or detector device shall be installed on each fire service where the Board determines that a hazard or potential hazard to the public water system exists. The type and location of the device shall be determined by the Board.

For Cross-Connection Control and Backflow Prevention, fire protection systems are classified by the Board as follows:

Table 3: Classification of Fire Protection Systems

Classification	Minimum Type of Protection Required AG – Air Gap Separation DC – Double Check Valve RP – Reduced Pressure Principle
<p>CLASS 1:</p> <p>Has wet or dry fire sprinkler system, serving consumer's buildings classified as low pollution hazard, service piping must be ductile iron cement lined (DACL). No unlined steel pipe; direct connection from Board's water main only; no fire department connection on the water supply side of the check valve; no tanks or physical connection to other water supplies or such supplies be available to the premises; no antifreeze, fomite, or other additives of any kind; sprinkler drains must discharge to atmosphere, dry wells, or other safe outlets.</p>	<p>DC</p>
<p>CLASS 2:</p> <p>Has sprinklers and/or hose connections with an electronic flow alarm, direct connection from the Board's water mains only; no tanks or reservoirs; no physical connection from other water supplies; no antifreeze or other additives of any kind; no connections to foam systems; no private fire hydrants; all sprinkler drains discharge to atmosphere, dry wells, or other safe outlets. The system has one or more private fire hydrants.</p>	<p>DC</p>



<p>CLASS 3:</p> <p>Has sprinklers, and/or hose connections with an electronic flow alarm, direct connection from Board's water mains, plus: elevated storage tanks; fire pumps taking suction from above ground covered reservoirs or tanks; and pressure tanks. (All storage facilities are filled by a metered connection to the Board's water main only.) Could have private hydrants.</p>	<p>DC</p>
<p>CLASS 4:</p> <p>Same as Class 2, except with an auxiliary water supply on or available to the premises; or an auxiliary supply located within 1,700 feet of a pumper connection. Could have private fire hydrants.</p>	<p>RP</p>
<p>CLASS 5:</p> <p>Directly supplied from Board's water mains, and interconnected with auxiliary supplies such as pumps taking suction from reservoirs exposed to contamination, or rivers and ponds; driven wells; mills or other industrial water systems; or where antifreeze, foaming substance, biological, or chemical additives are used.</p>	<p>RP or AG</p>
<p>CLASS 6:</p> <p>Has self-draining fire hydrants and/or hose connections without an electronic flow alarm, directly supplied from Board's water mains only, on premises presenting a pollution hazard such as apartment, townhome, and office complexes, schools, warehouses, or similar facilities, and where ground seepage of pollution but not toxic materials may occur.</p>	<p>RP or AG</p>



<p>CLASS 6A:</p> <p>Has self-draining fire hydrants and/or hose connection on premises presenting a health or system hazard such as chemical plants, petroleum plants, stock yards, bulk storage yards, sewer plants, or similar facilities, and where ground seepage of toxic materials may occur.</p>	<p>RP or AG</p>
--	-----------------

Booster Pumps

If a fire pump is required within the consumer's premises and is directly supplied from the Board's water mains, there is a possibility of creating a negative pressure in the water supply line. This condition is conducive to contaminating the water system by backflow through cross-connections or from leaks within the distribution system.

Booster pumps shall not be installed where there is not a satisfactory supply of water to maintain a minimum residual pressure of at least 20 PSI at peak demand. If a larger flow rate is needed, it must be obtained by installing larger water mains supplying the area or an on-site storage tank at the consumer's expense.

The installation of uncontrolled high-capacity fire pumps exceeding the carrying capacities of the Board's supply mains are prohibited. All booster pumps, unless supplied directly from the consumer's storage tank, must have appropriate controls to prevent the suction pressure from being lowered below 20 PSI.

Jockey Pumps

If a jockey pump (a pump with high-head and low-capacity characteristics) is required to maintain elevated pressure within the consumer's system, the pump must be located on the downstream side of an approved backflow prevention assembly as appropriate by class of the system (see Section 9).

Section 9: Installation of Devices

General Requirements

All backflow prevention assemblies and detector assemblies must be testable and repairable with two properly located approved shutoff valves and properly located test cocks. All assemblies shall be situated on the consumer's premises as close to the service connection and property line as practicable, generally within 6 – 10 feet of the meter setting. They shall be installed in the position as recommended by the manufacturer and should be protected from freezing.



For detailed instructions regarding installation specifications and freeze protection procedures please see the backflow assembly's manufacturer website. No intervening connections or by-passes shall be between the service connection and outlet side of the device, except for by-pass meter piping on detector assemblies. All assemblies must be tested within 30 days of installation and annually thereafter by an approved certified backflow prevention device tester.

Air-Gap Separation (AG)

Air gap separation as specified by the Board. An approved air gap separation shall be a distance of at least two (2) times the inside diameter of the supply pipe measured vertically above the overflow rim of the vessel, with a minimum distance of one (1") inch (2.54 cm) [see figure 9.02].

Dual Check Valve Backflow Preventer (DUC)

This device shall not be buried in earth but may be installed below ground in a vault or meter box to allow repairing of the device. A positive shut-off valve and union shall be adjacent to the inlet side of the device. This device is for residential use only and is not testable [see figure 9.03].

Double Check Valve Assembly (DC)

This assembly shall not be buried in earth but may be installed below ground in a vault provided the four test cocks are fitted with brass plugs. A positive shut-off valve shall be on the inlet and outlet sides of the assembly. Three (3) ball valve test cocks shall be on the assembly; a fourth test cock shall be on the inlet side of the No. 1 shutout valve. A union or flange should be adjacent to the inlet and outlet sides of the assembly [see figures 9.01 and 9.04].

Reduced Pressure Principle Backflow Preventer Assembly (RP)

This assembly shall not be buried or installed in below ground vaults. This assembly shall be installed above ground and so located to prevent any relief or vent opening from being submerged at any time. When installed in above ground vaults, there shall be drain outlets to the outside of the vault at grade level. The assembly shall be positioned in the vault so the relief or vent opening is a minimum of twelve inches 12" above final grade level outside the vault. The drain outlet in the vault shall be a minimum of four (4) times the area of the relief or vent opening on the device. A positive shut-off valve shall be on the inlet and outlet sides of the device. Three (3) ball valve test cocks shall be on the device; a fourth test cock shall be on the inlet side of the No. 1 shutout valve. A union or flange should be adjacent to the inlet side of the device [see figures 9.11 and 9.05].

Double Check Detector Assembly (DCDA)

This device is for fire systems only and is an approved backflow preventer. The device may be installed below ground in a vault as specified by the Board. The



four ball valve test cocks on the device shall be fitted with brass plugs. A union or flange should be adjacent to the inlet and outlet side of the device [see figure 9.07].

Reduced Pressure Principle Detector Assembly (RPDA)

This device is for fire systems only and is an approved backflow preventer. This device shall not be buried or installed in below ground vaults. The device shall be installed above ground and so located to prevent any relief or vent opening from being submerged at any time. When installed in above ground vaults, as specified by the Board; there shall be a drain outlet to the outside of the vault at grade level. The drain outlet(s) shall be a minimum of four (4) times the area of the relief or vent opening on the device. A union or flange should be adjacent to the inlet side of the device [see figure 9.08].

Pressure Vacuum Breaker (PVB)

An assembly consisting of an independently operating, internally loaded check valve, an independently operating, loaded air-inlet valve located on the discharge side of the check valve, with properly located resilient-seated test cocks and tightly closing resilient-seated shutoff valves attached at each end of the assembly designed to be operated under pressure for prolonged periods of time to prevent backsiphonage. The pressure vacuum breaker may not be subjected to any backpressure [see figure 9.09 and figure 9.10].

SECTION 9 (CONTINUED)
 TYPICAL BACKFLOW PREVENTION DEVICE INSTALLATIONS

DOUBLE CHECK VALVE ASSEMBLY (DC) INSTALLATION
 SEE SEC. 9.4

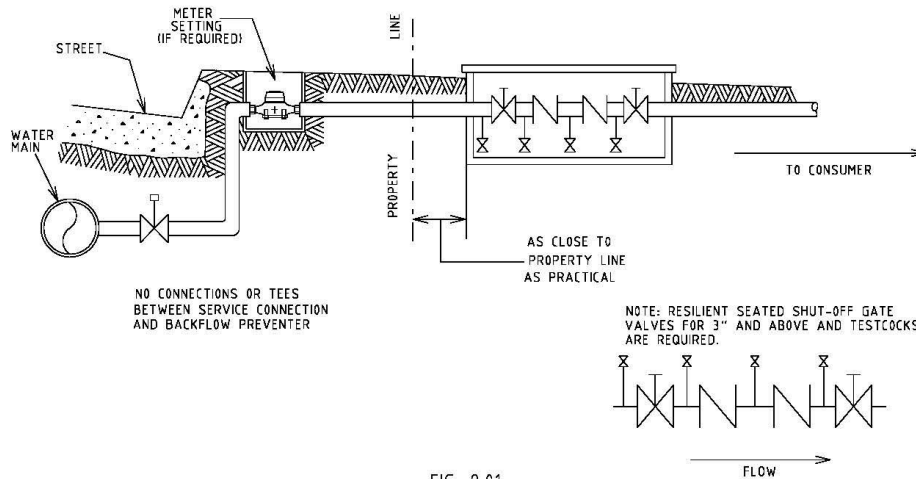
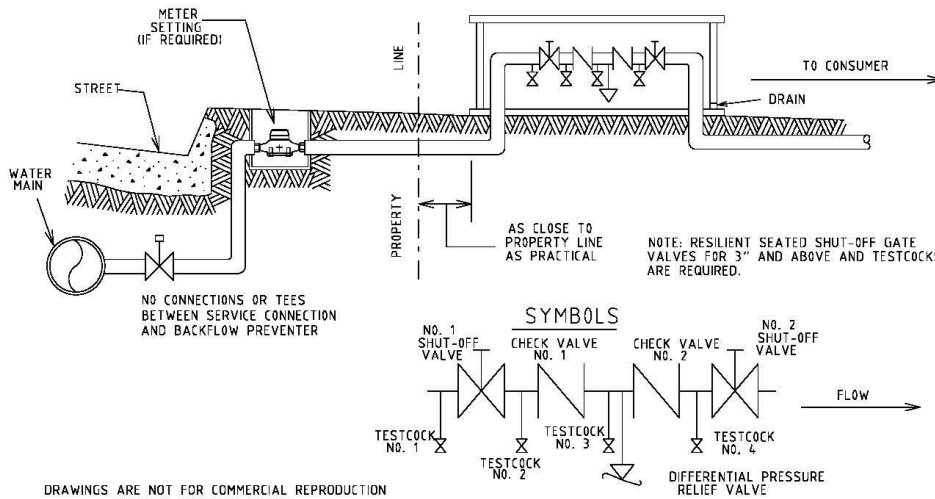

FIG. 9.01

REDUCED PRESSURE PRINCIPLE BACKFLOW ASSEMBLY (RP) INSTALLATION
 SEE SEC. 9.5



DRAWINGS ARE NOT FOR COMMERCIAL REPRODUCTION
 CENTRAL ALABAMA WATER

FIG. 9.11

NOVEMBER 1993
 REV. JUNE 2000

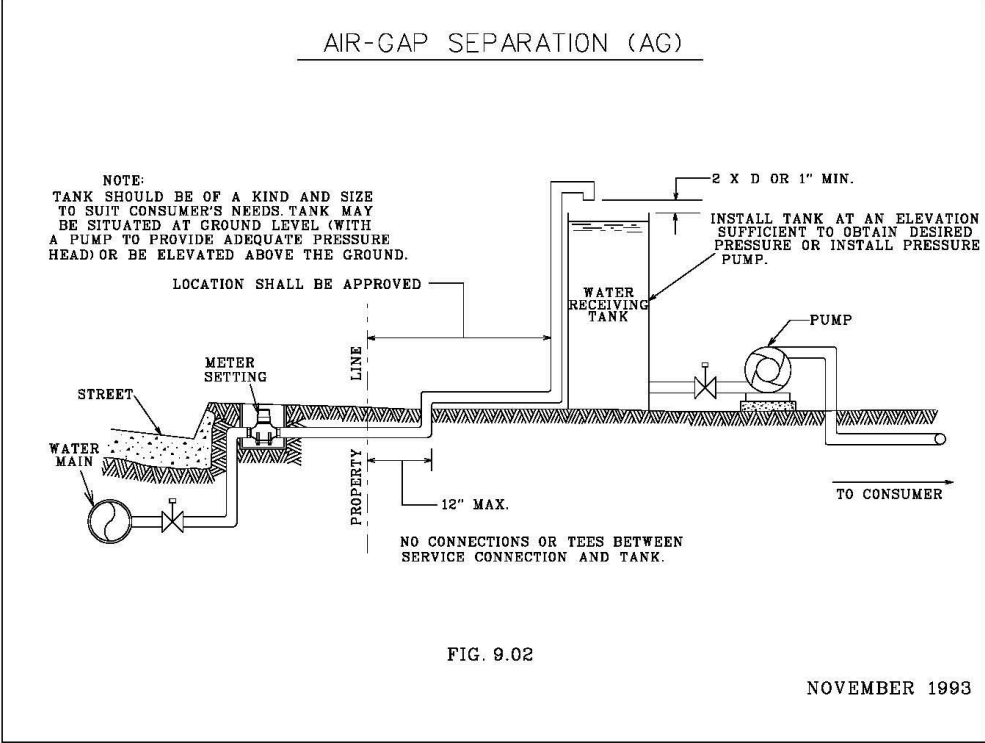
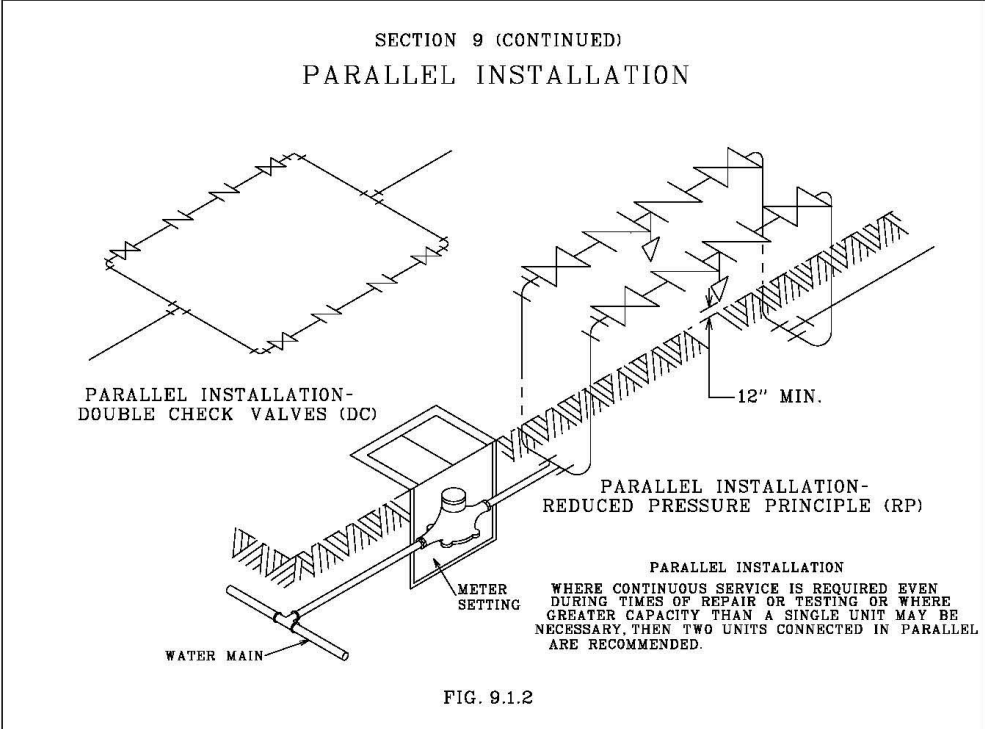

SECTION 9 (CONTINUED)
 DUAL CHECK VALVE (DUC) BACKFLOW PREVENTER INSTALLATION

NOTE:
 FOR RESIDENTIAL USE ONLY

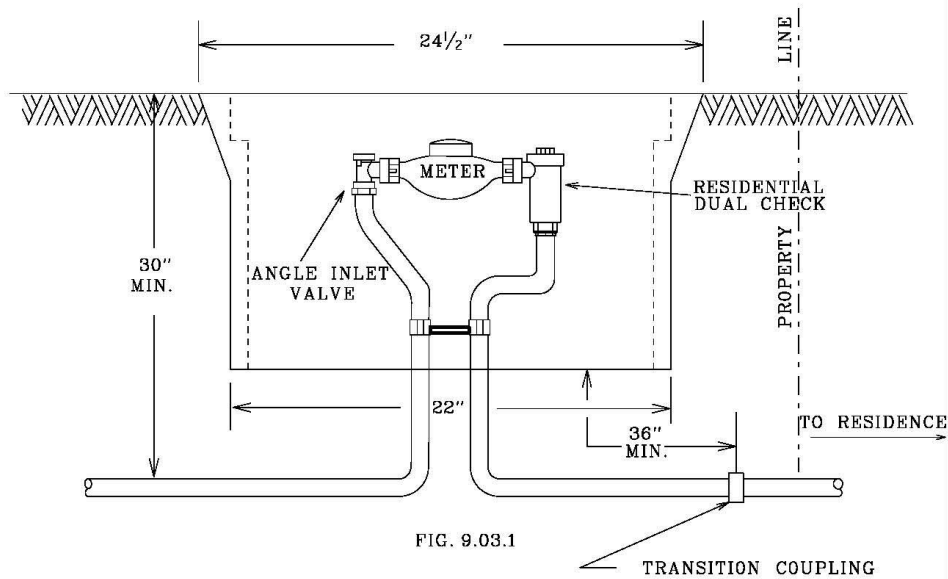
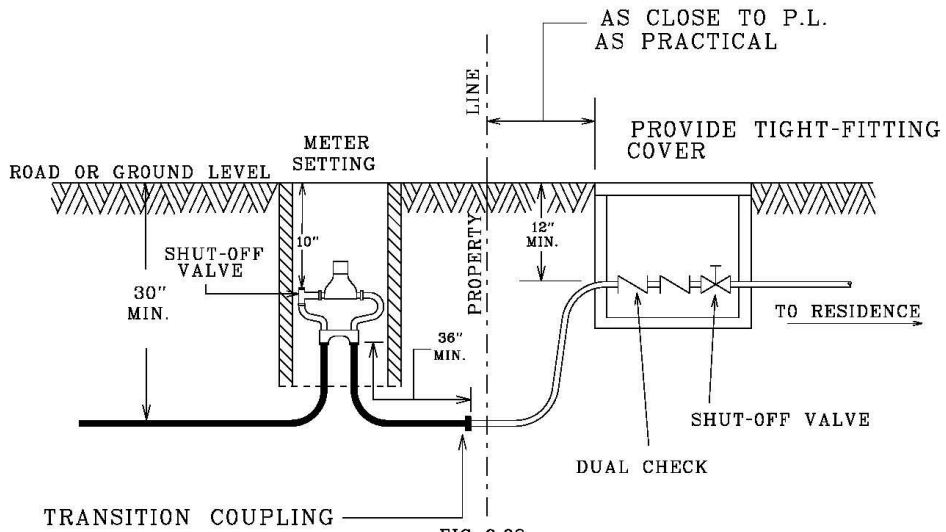

NOVEMBER 1993

SECTION 9 (CONTINUED)
 DOUBLE CHECK VALVE (DC) BACKFLOW
 PREVENTER TYPICAL INSTALLATION FOR 2½" AND LARGER

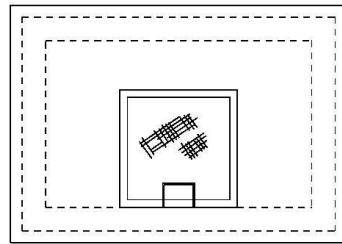

PLAN

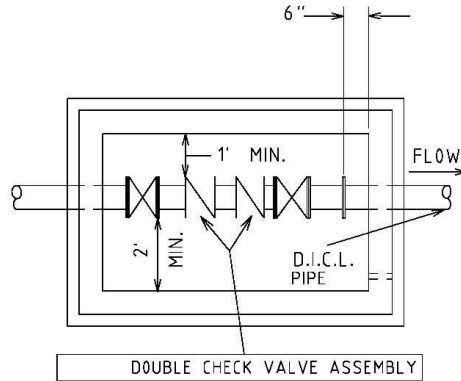

DOUBLE CHECK VALVE ASSEMBLY
 SECTIONAL PLAN

- NOTES:
1. THE TYPE OF VAULT CONSTRUCTION IS OPTIONAL WITH OWNER. THE OBJECTIVES ARE PROTECTION FOR THE ASSEMBLY, ADEQUATE CLEARANCE AND EASY ACCESS FOR MAINTENANCE AND TESTING.
 2. THIS DRAWING IS STRICTLY TO ILLUSTRATE MINIMUM CLEARANCES AND DIMENSIONS OF THE VAULT. FOR SPECIFIC DESIGN DETAILS, REFERENCE ATTACHED SPECIFICATION.
 3. PREFABRICATED CONCRETE VAULTS MAY BE INSTALLED. REFER TO APPROVED MANUFACTURERS OF BACKFLOW PREVENTER ASSEMBLY STRUCTURES ON PAGE 6 OF THE ATTACHED SPECIFICATIONS.

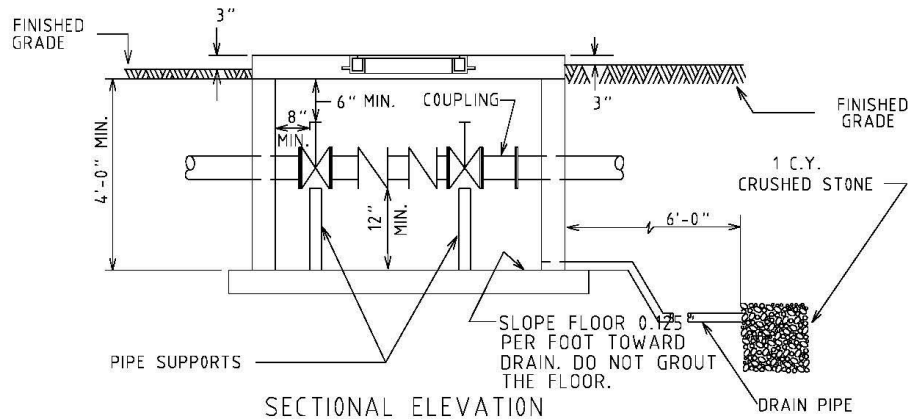

SECTIONAL ELEVATION

FIG. 9.04

DRAWINGS ARE NOT FOR COMMERCIAL REPRODUCTION
 CENTRAL ALABAMA WATER

FEBRUARY 2000
 REV. JUNE 2000

DRAWN BY VLD
 OCTOBER 1999

TYPICAL INSTALLATION FOR REDUCED PRESSURE PRINCIPLE (RP) BACKFLOW PREVENTERS

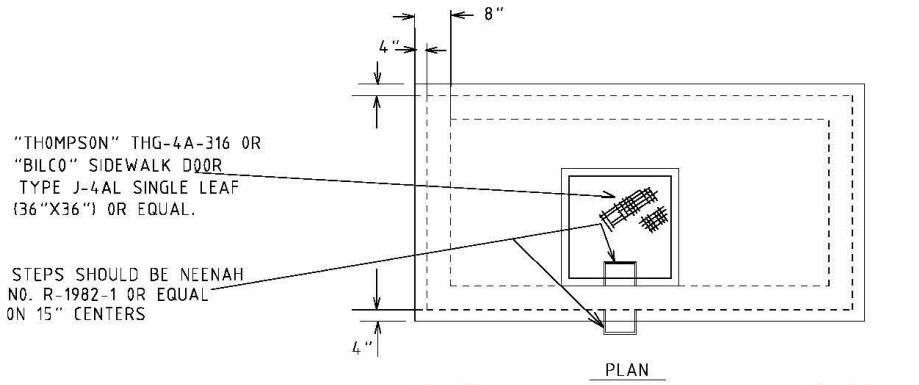

- NOTES:
1. THE TYPE OF VAULT CONSTRUCTION AND OUTSIDE FINISH IS OPTIONAL WITH OWNER. THE OBJECTIVES ARE PROTECTION FOR THE ASSEMBLY, ADEQUATE CLEARANCE, EASY ACCESS FOR MAINTENANCE AND TESTING.
 2. VAULT CONSTRUCTION SHOULD BE OF CONCRETE BLOCKS OR FORMED WITH CONCRETE, 6" THICK.
 3. PREFABRICATED INSULATED COVERS FOR RP BACKFLOW PREVENTERS MAY BE SUBSTITUTED. REFER TO APPROVED MANUFACTURERS OF BACKFLOW PREVENTER ASSEMBLY STRUCTURES ON PAGE 6 OF THE ATTACHED SPECIFICATIONS.
 4. DRAIN HOLE SHALL BE MINIMUM (4) TIMES AREA OF RELIEF OPENING OF DEVICE.

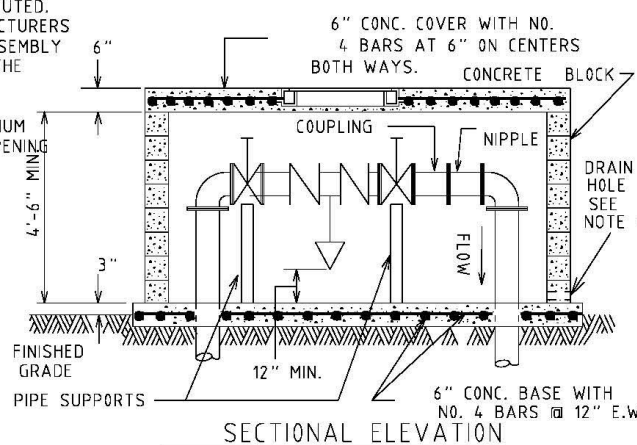
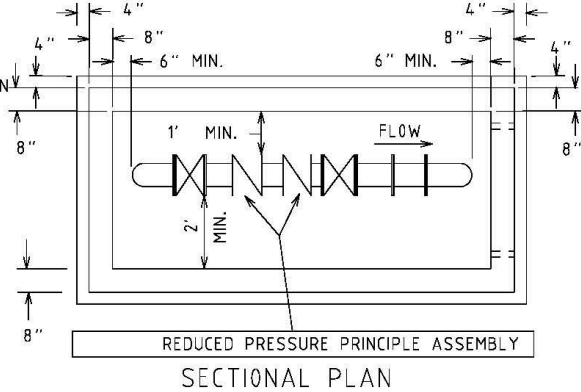
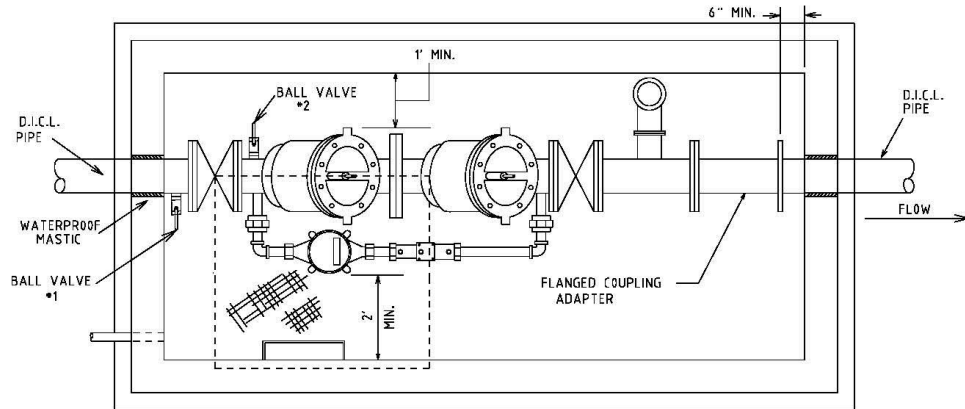

FIG. 9.05

DRAWINGS ARE NOT FOR COMMERCIAL REPRODUCTION
CENTRAL ALABAMA WATER

NOVEMBER 1993
REV. JUNE 2000

SECTION 9 (CONTINUED)
 DETECTOR DOUBLE CHECK VALVE
 DETAIL INSTALLATION



SECTIONAL PLAN

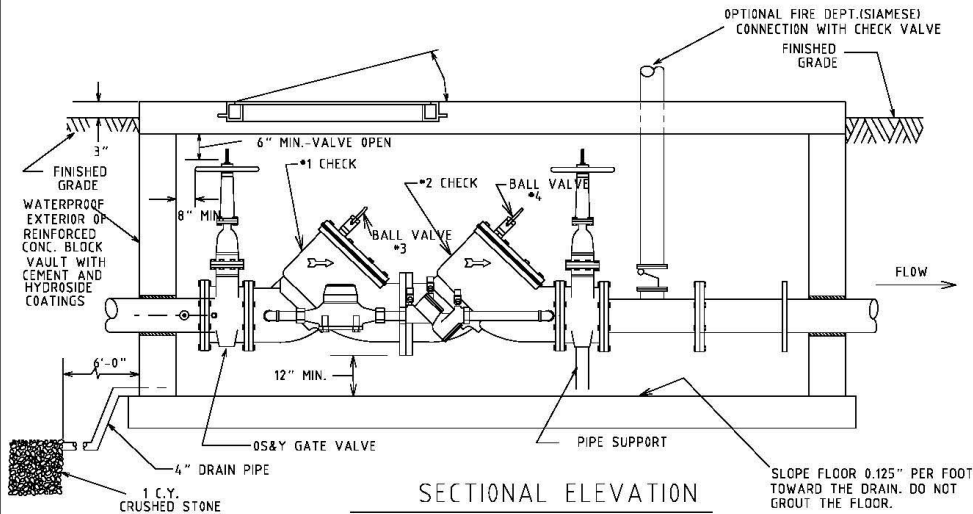

SECTIONAL ELEVATION

NOTES:

1. DETECTOR DOUBLE CHECK VALVE ASSEMBLY MUST BE APPROVED AND MEET THE LATEST STANDARDS OF A.S.S.E. STD. NO. 1048, AWWA STD. NO. C-51089, FM, UL CLASSIFIED, AND TESTED AND CERTIFIED UNDER USC'S FCC&HR. AS MANUFACTURED BY WATTS REGULATOR-NO. 709 OR 770DCDA SERIES, COMBRACO-NO. 40-600 SERIES, FEBCO-MODEL NO. 806, HERSEY-MODEL DDCII, AMES CO. MODEL NO. 3000 OR AN APPROVED EQUAL ACCEPTED BY THE WATER BOARD.
2. NO VALVES SHALL BE ON BY-PASS PIPING ASSEMBLY THAT WOULD PROHIBIT FLOW THROUGH THE 3/8" METER.
3. 3/8" METER ON BY-PASS ASSEMBLY MUST READ THE 3/8" METER. WILL BE FURNISHED BY THE BIRMINGHAM WATER WORKS BOARD.
4. THIS DRAWING IS STRICTLY TO ILLUSTRATE MINIMUM CLEARANCES AND DIMENSIONS OF THE VAULT. FOR SPECIFIC DESIGN DETAILS, REFERENCE ATTACHED SPECIFICATION.
5. PREFABRICATED CONCRETE VAULTS MAY BE INSTALLED. REFER TO APPROVED MANUFACTURERS OF BACKFLOW PREVENTER ASSEMBLY STRUCTURES ON PAGE 6 OF THE ATTACHED SPECIFICATIONS.

DRAWINGS ARE NOT FOR COMMERCIAL REPRODUCTION
 CENTRAL ALABAMA WATER

DRAWN BY VLD
 OCTOBER 1999

FIG. 9.07

FEBRUARY 2000
 REV. JUNE 2000

SECTION 9 (CONTINUED)
 PARALLEL INSTALLATION DETAIL
 DETECTOR DOUBLE CHECK AND DOUBLE CHECK VALVE ASSEMBLIES

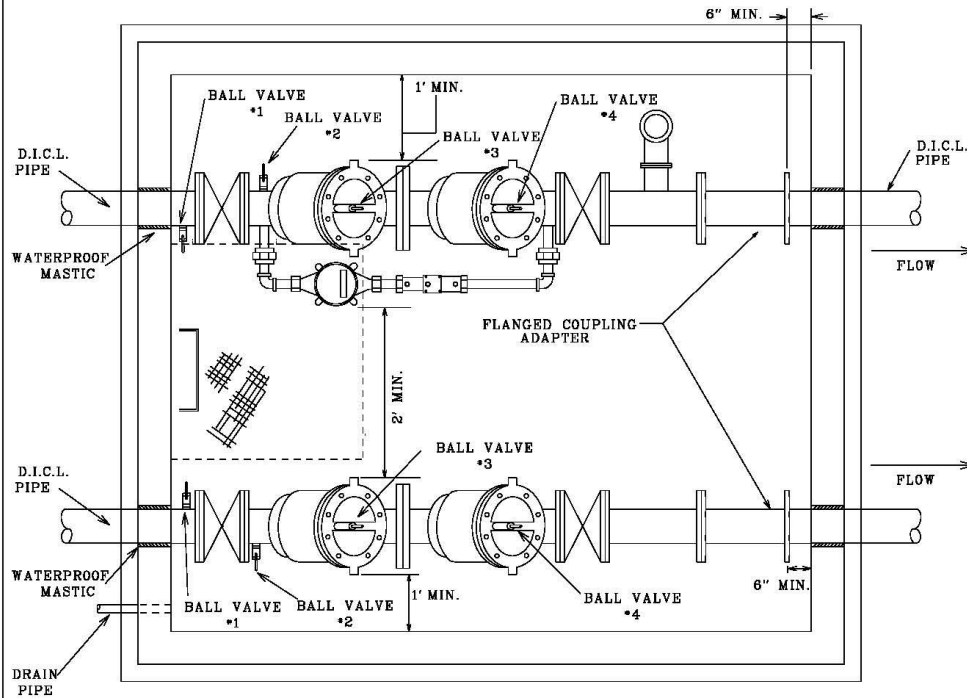

SECTIONAL PLAN

NOTES:

1. FOR SECTIONAL ELEVATION REFER TO DETECTOR DOUBLE CHECK VALVE DETAIL INSTALLATION (FIG. 9.07, PAGE 29) AND DOUBLE CHECK VALVE (DC) BACKFLOW PREVENTER TYPICAL INSTALLATION (FIG. 9.04, PAGE 26).
2. ALL NOTES AND SECTIONAL ELEVATION DETAILS ON PAGES 26 AND 29 MUST BE ADHERED TO.

DRAWINGS ARE NOT FOR COMMERCIAL REPRODUCTION
 CENTRAL ALABAMA WATER

FEBRUARY 1993
 REVISED MARCH 2001

FIG. 9.07.1

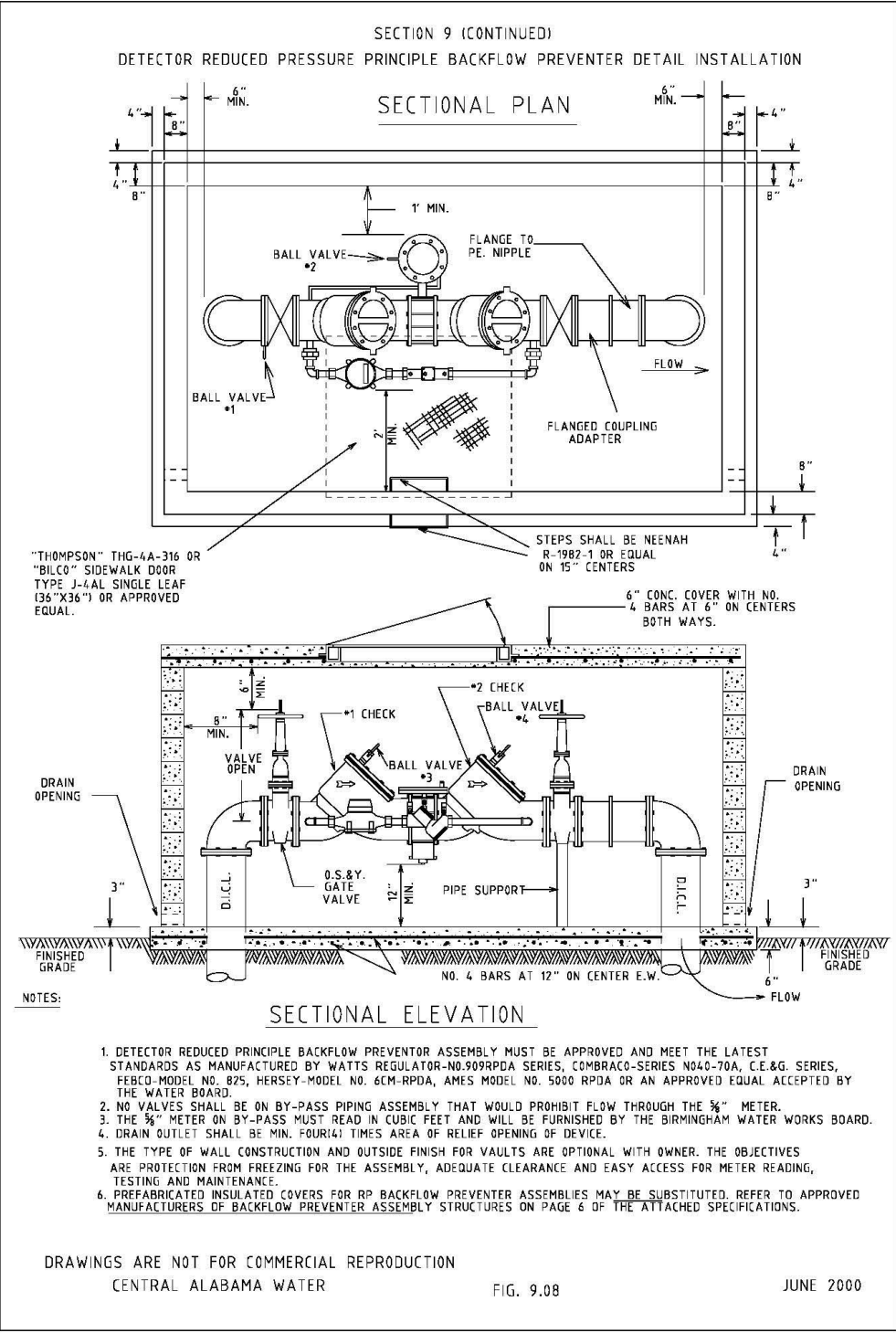

PRESSURE VACUUM BREAKER (PVB) DETAIL

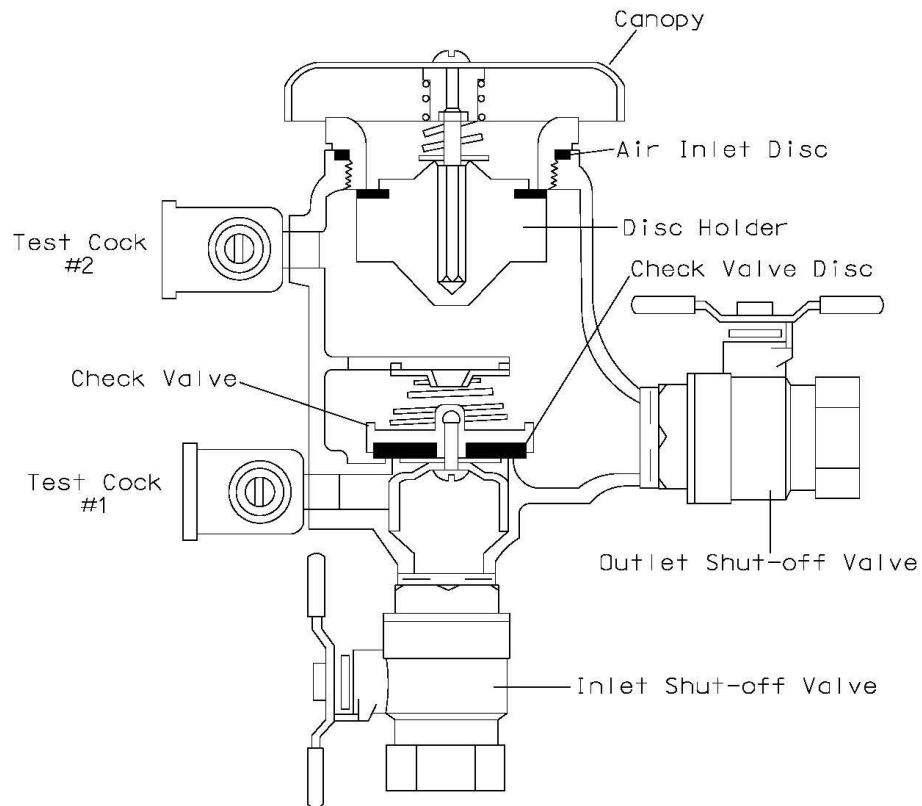

(1) The PVB cannot be subjected to backpressure.

The check valve must be forced open in the normal direction of flow. During backsiphonage, the air inlet opens and allows atmospheric pressure into the assembly.

PRESSURE VACUUM BREAKER (PVB) INSTALLATION

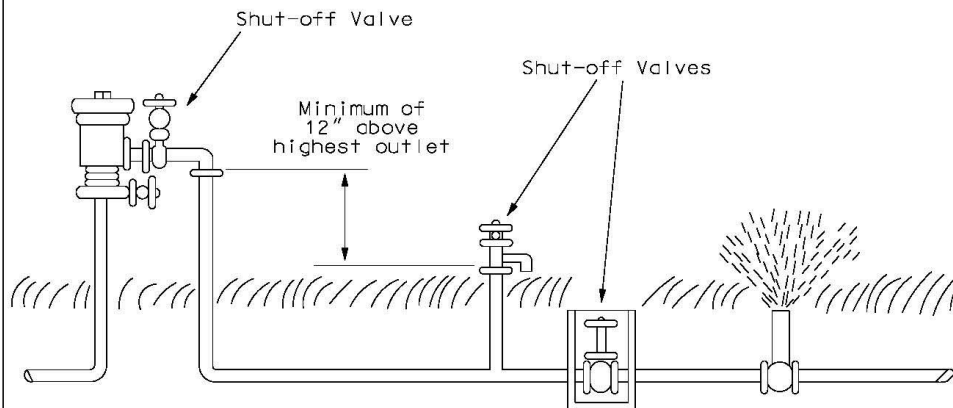

- (1) The check valve must be forced open in the normal direction of flow. During backsiphonage, the air inlet opens and allows atmospheric pressure into the assembly.
- (2) The PVB must be installed so that the critical level is 12 inches above the highest point in the system.
- (3) Lawn irrigation systems are classified as a high hazard.
- (4) Because the pressure vacuum breaker can be subjected to continuous pressure, it is acceptable to have a shut-off valve downstream.

Shut-off Valves are allowed Downstream on Pressure Vacuum Breakers. Because the pressure vacuum breaker can be subjected to continuous pressure, it is acceptable to have a shut-off valve downstream.